

TL - TFL ROD SERIES WITH SAFETY LEVER (LIGHT PERFORMANCE)

The sizes of this series are also produced in stainless steel and are shown below in red.

Material:

Galvanized sheet metal or **AISI 304 stainless steel**

Riveted pivots and rod:

Galvanized steel or **AISI 304 stainless steel**

Handles:

Red polyurethane resistant to oils, grease and other chemical agents.

Performance:

Form TL and **form TLX** is supplied with a pivot for traction and a hooking bracket;

Form TFL and **form TFLX** it is possible to choose from three different optional rods (to be ordered separately):

Eye bolt rod "TG", T-shaped rod "TT", Hook Rod "U" (see Page 47).

Features and applications:

The tools of this series ensure a perfect closing of lids.

The position of the threaded rod can be adjusted within a certain range (see drawing) to meet the requirements of use.

FORM TL



PATENTED

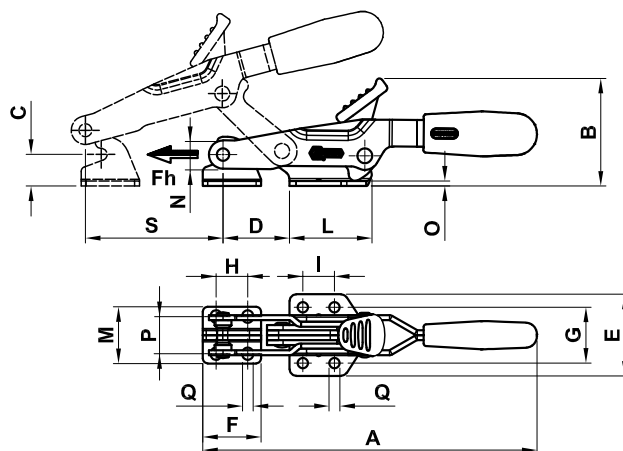

FORM TFL



PATENTED

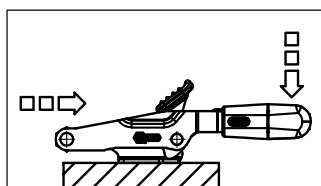
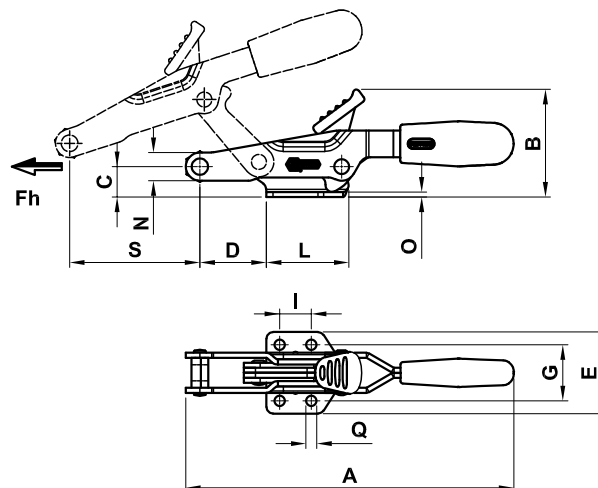

Code	Description	Stainless steel Code	Description	A	B	C	D	E	F	G	H	I	L	M	N	O	P	Q	S	Fh (daN)	gr.
AL430	33/TL	AS440	33/TLX	200	65	19	40	49	35	33,5	19	19	50	34	17	3	22,3	6,5	83	500	441
AL435	33/TFL	AS442	33/TFLX	197	65	19	40	49		33,5		19	50		17	3		6,5	83	500	413
AL440	43/TL	AS444	43/TLX	248	74	28	51	63	50	45	31	32	61	41	20	4	25,4	8,5	90	1000	834
AL445	43/TFL	AS446	43/TFLX	242	74	28	51	63		45		32	61		20	4		8,5	90	1000	719