

FORM T

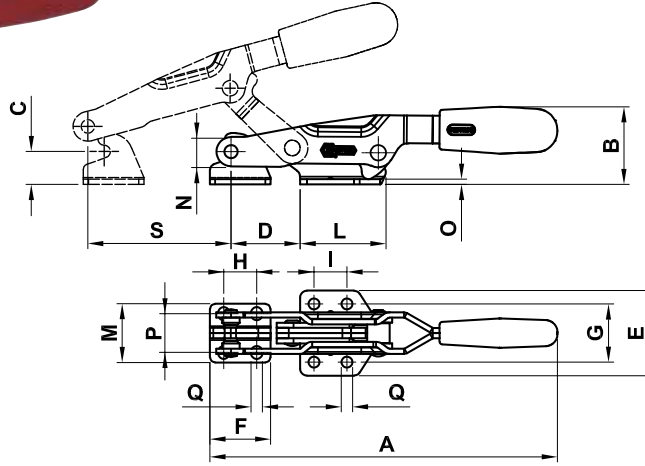

PATENTED



FORM TF



PATENTED

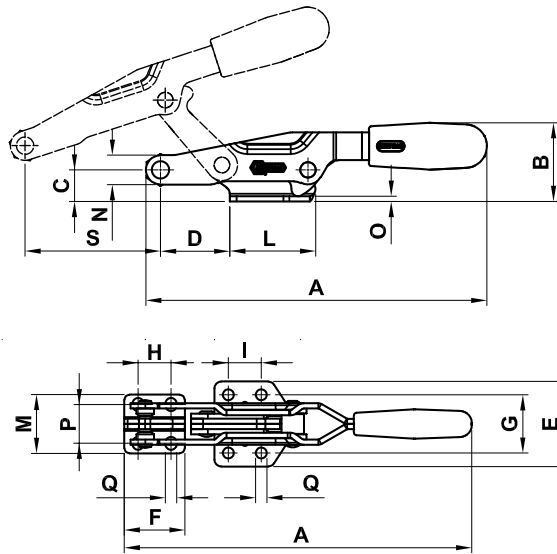

T - TF ROD SERIES (LIGHT PERFORMANCE)

The sizes of this series are also produced in stainless steel and are shown below in red.

Material:
Galvanized sheet metal or **AISI 304 stainless steel**

Riveted pivots and rod:
Galvanized steel or **AISI 304 stainless steel**

Handles:
Red polyurethane resistant to oils, grease and other chemical agents.

Performance:
Form T and **form TX** is supplied with a pivot for traction and a hooking bracket;
Form TF and **form TFX** it is possible to choose from three different optional rods (to be ordered separately): Eye bolt rod "TG", T-shaped rod "TT", Hook Rod "U" (See page 49).

Features and applications:
The tools of this series ensure a perfect closing of lids.
The position of the threaded rod can be adjusted within a certain range (see drawing) to meet the requirements of use.
A special grease is placed between two contacting surfaces during assembly.

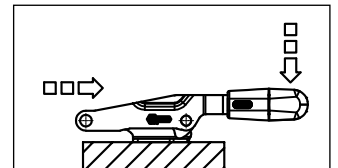

| Code | Description | Stainless steel Code | Description | A | B | C | D | E | F | G | H | I | L | M | N | O | P | Q | S | Fh (daN) | gr. |
|-------|-------------|----------------------|-------------|-----|----|----|----|----|----|------|----|----|----|----|----|---|------|-----|-----|----------|-----|
| AL410 | 33/T | AS430 | 33/TX | 200 | 45 | 19 | 40 | 49 | 35 | 33,5 | 19 | 19 | 50 | 34 | 17 | 3 | 22,3 | 6,5 | 83 | 500 | 422 |
| AL415 | 33/TF | AS432 | 33/TFX | 197 | 45 | 19 | 40 | 49 | | 33,5 | | 19 | 50 | | 17 | 3 | | 6,5 | 83 | 500 | 394 |
| AL420 | 43/T | AS436 | 43/TX | 248 | 56 | 28 | 51 | 63 | 50 | 45 | 31 | 32 | 61 | 41 | 20 | 4 | 25,4 | 8,5 | 110 | 1000 | 811 |
| AL425 | 43/TF | AS438 | 43/TFX | 242 | 56 | 28 | 51 | 63 | | 45 | | 32 | 61 | | 20 | 4 | | 8,5 | 90 | 1000 | 696 |