

T - TF ROD SERIES (LIGHT PERFORMANCE)

Material:

Zinc coated plates

Riveted pivots and rod:

Galvanized steel

Handles:

Red polyurethane resistant to oils, grease and other chemical agents.

Performance:

Form T is supplied with a pivot for traction;

Form TF is supplied with a coupling hook for traction

Features and applications:

The tools of this series ensure a perfect closing of lids.

The position of the threaded rod can be adjusted within a certain range (see dimension "D") to meet the requirements of use.

A special grease is placed between two contacting surfaces during assembly.

FORM T

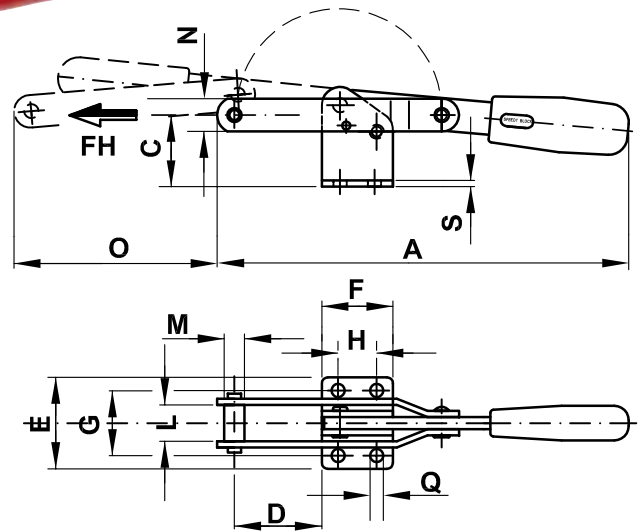

FORM TF

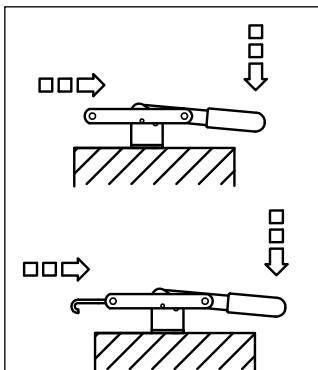
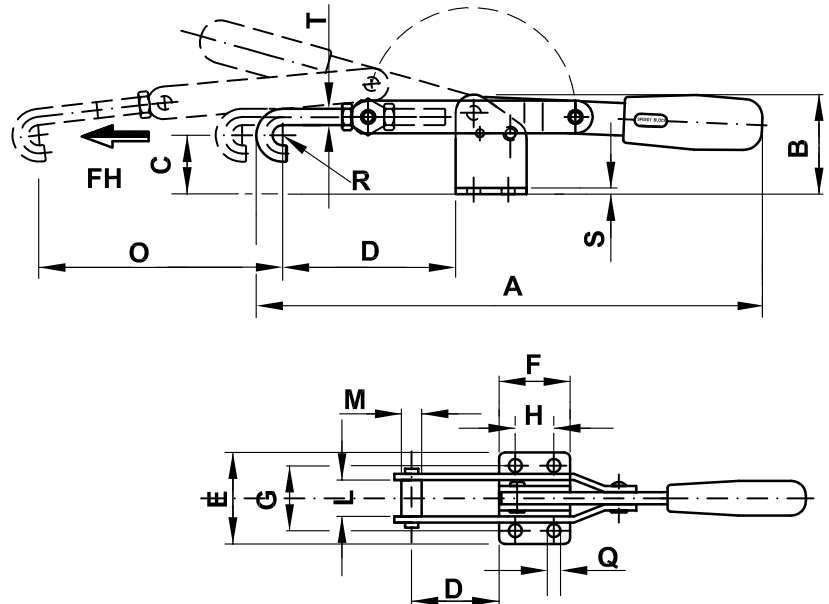

Code	Description	A	B	C	D	E	F	G	H	L	M	N	O	Q	R	S	T	Fh (daN)	gr.
AL200	200/T	203	49	36	43	45	35	32	19	18	10	16	100	6,5	3			200	300
AL205	200/TF	251	49	29	85÷105	45	35	32	19	18		16	100	6,5	5	3	M8	200	380
AL300	300/T	225	49	36	43	60	48	45	32	21	10	18	100	8,5	3			300	460
AL305	300/TF	277	49	25	90÷115	60	48	45	32	21		18	100	8,5	6	3	M10	300	560
AL400	400/T	275	60,5	43	45,5	84	54	60,5	28,5	26	14	25	160	10,5		5		400	1000
AL405	400/TF	339	60,5	30	107÷129	84	54	60,5	28,5	26		25	160	10,5	7	5	M12	400	1200