

# STRAIGHT-LINE ACTION SERIES



## PUSH AND PULL STRAIGHT-LINE ACTION SERIES

The sizes of this series are also produced in stainless steel and are shown below in red.

**Material:** Galvanized steel or **AISI 304 stainless steel**

**Riveted pivots, push bar, bushing fixing screws and sliding bearing and ring:**

Galvanized steel or **AISI 304 stainless steel**

**Sliding bushes:** Galvanized steel or **AISI 303 steel**

**Mounting bracket (to be ordered separately):** Galvanized steel or **AISI 304 stainless steel**

**Handles:** Red polyurethane resistant to oils, grease and other chemical agents.

**Spindles:** To be ordered separately (see Accessories on page 87)

### Features and applications:

Thanks to the front thread, the tools of this series can be mounted directly on the equipment used and the control lever can be turned to the most favourable position for use.

The mounting bracket (order separately) increases the possibility of use.

A special grease is placed between two contacting surfaces during assembly.

## FORM AS

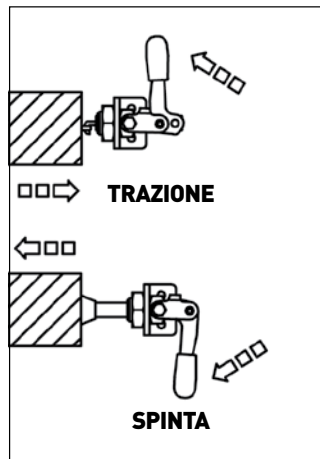
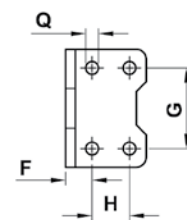
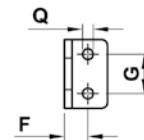
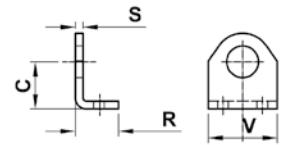
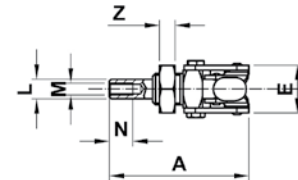
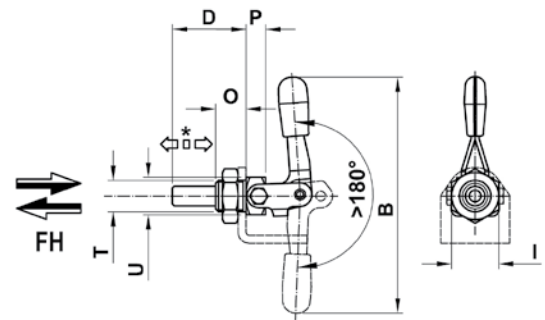

Code	Description	Stainless steel Code	Description	A	B	D	E	I	L	M	N	O	P	T	U	Z	*	Fh (daN)	gr.
AG401	80/AS	AS401	80/ASX	71	120	38	24	24	10	M6	12	15,5	10	M16X1,5	19	8	21	300	135
AG406	165/AS	AS406	165/ASX	113	194	59	28	30	12	M8	15	20	16	M20X1,5	22	9	38	540	335
AG411	340/AS	AS411	340/ASX	173	256	90	38	36	16	M10	18	22	28	M24X2	30	10	66	700	835

Code	Description	Stainless steel Code	Description	C	F	G	H	Q	R	S	V	Supporto per modello
AG416	30080	AS416	30080X	24	8	20	-	5,5	22	4	35	80/AS - 80/ASX
AG421	30165	AS421	30165X	32	13,5	41	19	6,5	41	5	60	165/AS - 165/ASX
AG426	30340	AS426	30340X	48	19	55	25	8,5	59	5	75	340/AS - 340/ASX

