

## FORM MF

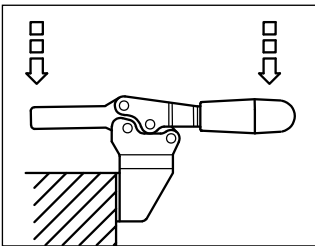
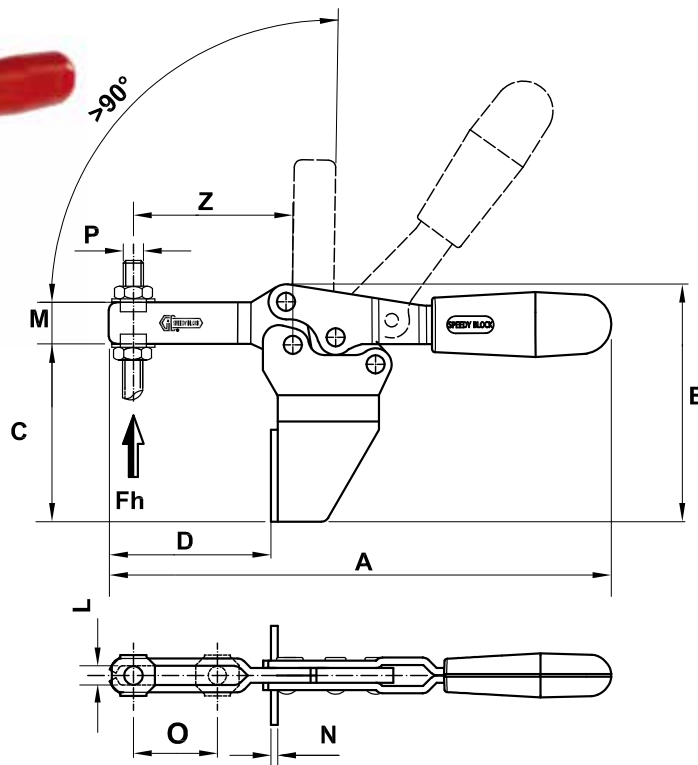

### HORIZONTAL SERIES WITH FRONT BASE

Some sizes of this series are also produced in stainless steel and are shown below in red.

**Material:**

Galvanized steel or **AISI 304 stainless steel**

**Riveted pivots:**

Galvanized steel or **AISI 304 stainless steel**

**Supporting bushes:**

Hardened and ground steel (for sizes  $\geq 355$ )

**Handles:**

Red polyurethane resistant to oils, grease and other chemical agents.

**Performance:**

Form MF and **form MFX** with open clamping lever and two flanged washers.

**Spindles:**

To be ordered separately (see Accessories on page 87).

**Features and applications:**

The main feature of this series is the front mount; these tools are designed to prevent the operator's fingers from being crushed by the levers when opening. During the closing, the clamping lever is guided laterally to ensure greater stability against possible transverse stresses.

A special grease is placed between two contacting surfaces during assembly.

Code	Description	Stainless steel Code	Description	A	B	C	D	E	F	G	H	L	M	N	O	P	Q	Z	Fh (daN)	gr.
AD076	75/MF	DS076	75/MFX	118	62	45	36	30	25,5	18	13,5	5,5	11	2	20	M5	4,5	36	90	105
AD136	130/MF	DS136	130/MFX	171,5	85	64	54	39	35	26	22	6,5	16	2,5	32	M6	5,5	55	100	240
AD271	230/MF	DS271	230/MFX	196	102	77	62	43	40	28,5	24	8,5	18	3	37	M8	6,5	62	170	400
AD371	355/MF			269	135	102	96	52	52	32	32	10,5	22	3,5	58	M10	8,5	98	180	830

