

FORM LLB

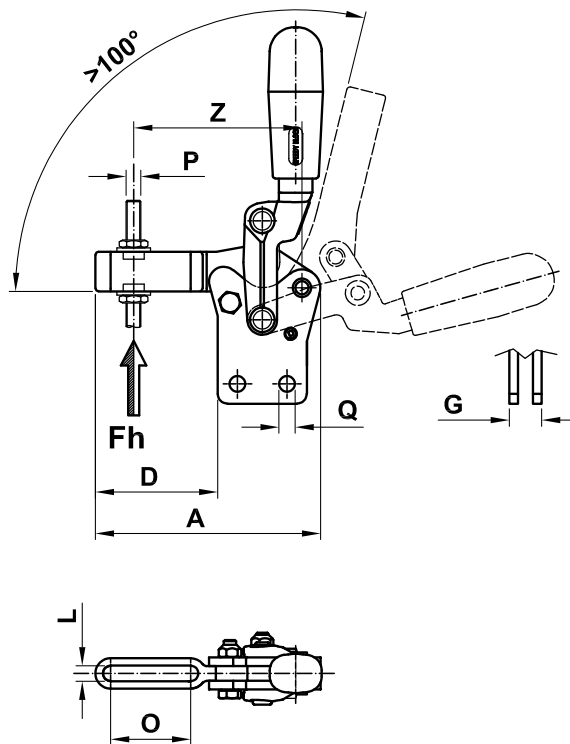

REINFORCED VERTICAL SERIES WITH STRAIGHT BASE

Material:

Phosphated steel.

Pivots:

Hardened and ground steel.

Supporting bushes:

Hardened and ground steel.

Handles:

Red polyurethane resistant to oils, grease and other chemical agents.

Performance:

Form B with open clamping lever and two flanged washers.

Form F with eyelet clamping lever to insert the spindle.

Spindles:

To be ordered separately (see Accessories on page 87).

Features and applications:

The clamping levers and control levers are forged; the guide of the clamping lever is adjustable.

This series is usually used for medium and heavy duty clamping works, on welding jigs, carpentry works, moulds and generally when high clamping forces are needed and when there is strong repetitiveness of movements.

FORM LLF

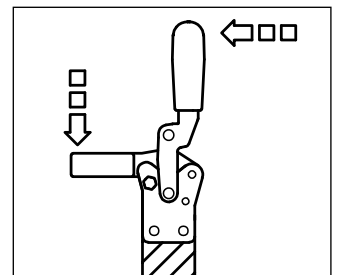
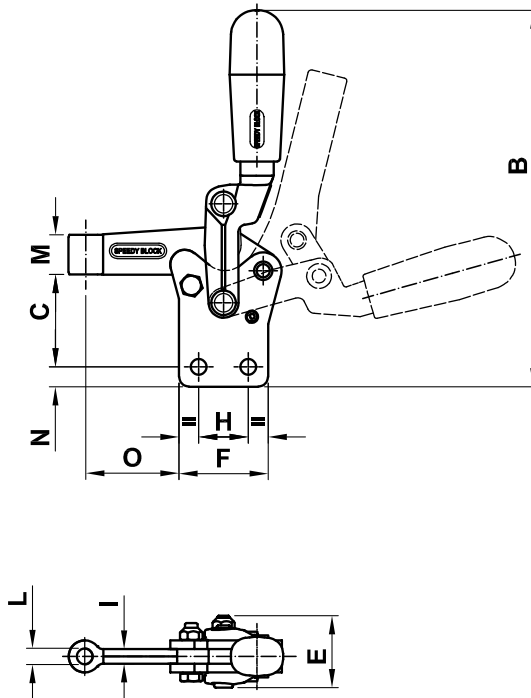

Code	Description	A	B	C	D	E	F	G	H	I	L	M	N	O	P	Q	Z	Fh (daN)	gr.
AA605	LLB01	91	152	37,5	49	29	36	13	20		6,3	16	8	32	M6	6,5	77	220	330
AA615	LLF01	86	152	37,5	44	29	36	13	20	6	6,5	16	8	38	M6	6,5		220	325
AA635	LLB02	129,5	235	59,5	64	42	54	20	30		10,3	24	10	34	M10	8,5	107	440	1200
AA645	LLF02	129,5	235	59,5	64	42	54	20	30	10	10,5	24	10	54,5	M10	8,5		440	1200
AA665	LLF03	161	301	78	74	52	75	24	55	12	12,5	30	10	62	M12	10,5		850	1200
AA685	LLF04	203	330	88,5	96	68	90	32	65	16	16,5	35	17,5	80	M16	12,5		1540	4510