

## REINFORCED VERTICAL SERIES WITH FOLDED BASE

### Material:

Phosphated steel.

### Pivots:

Hardened and ground steel.

### Supporting bushes:

Hardened and ground steel.

### Handles:

Red polyurethane resistant to oils, grease and other chemical agents.

### Performance:

Form A with open clamping lever and two flanged washers.

Form E with eyelet clamping lever to insert the spindle.

### Spindles:

To be ordered separately (see Accessories on page 87).

### Features and applications:

The clamping levers and control levers are forged; the guide of the clamping lever is adjustable.

This series is usually used for medium and heavy duty clamping works, on welding jigs, carpentry works, moulds and generally when high clamping forces are needed and when there is strong repetitiveness of movements.

## FORM LLA

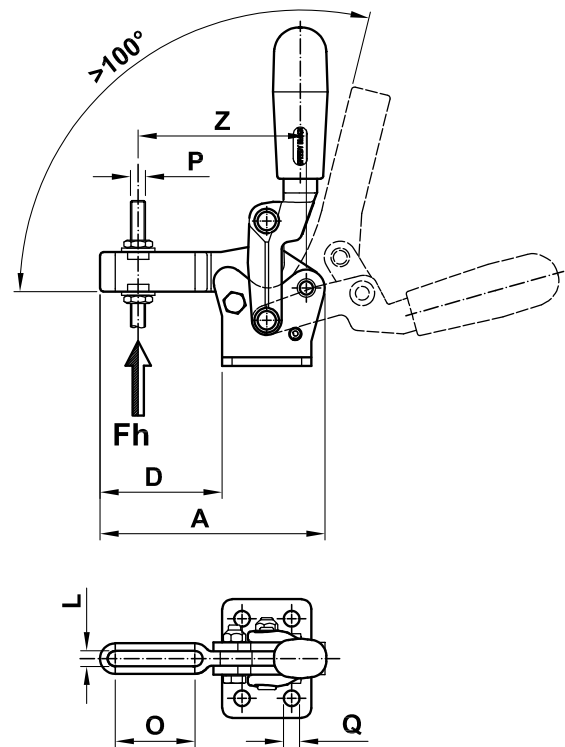

## FORM LLE

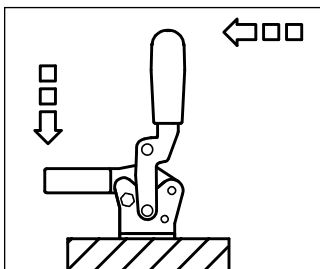
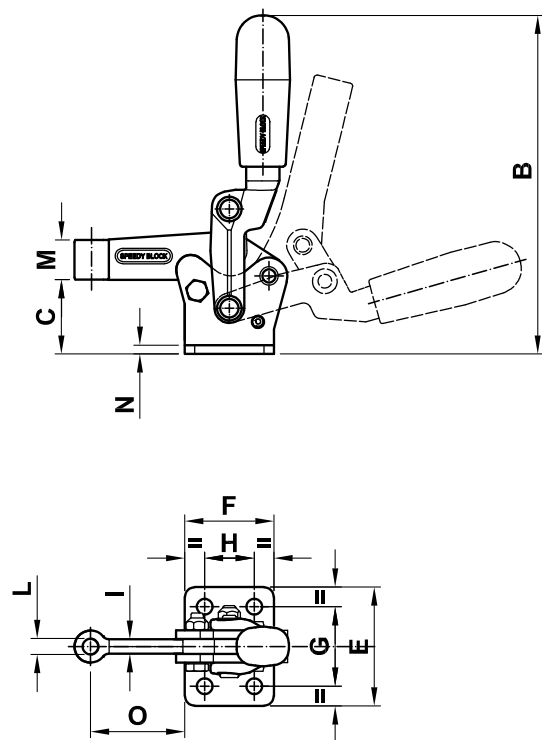

Code	Description	A	B	C	D	E	F	G	H	I	L	M	N	O	P	Q	Z	Fh (daN)	gr.
AA600	LLA01	91	136,5	30	49	48	36	32	20		6,3	16	3,5	32	M6	6,5	77	220	330
AA610	LLE01	86	136,5	30	44	48	36	32	20	6	6,5	16	3,5	38	M6	6,5		220	325
AA630	LLA02	129,5	215	50	64	65	54	45	30		10,3	24	5	34	M10	8,5	107	440	1200
AA640	LLE02	129,5	215	50	64	65	54	45	30	10	10,5	24	5	54,5	M10	8,5		440	1200
AA660	LLE03	161	280	67	74	75	75	55	55	12	12,5	30	6	62	M12	10,5		850	1200
AA680	LLE04	203	330	76,5	96	100	90	65	65	16	16,5	35	8	80	M16	12,5		1540	4510