

FORM AV

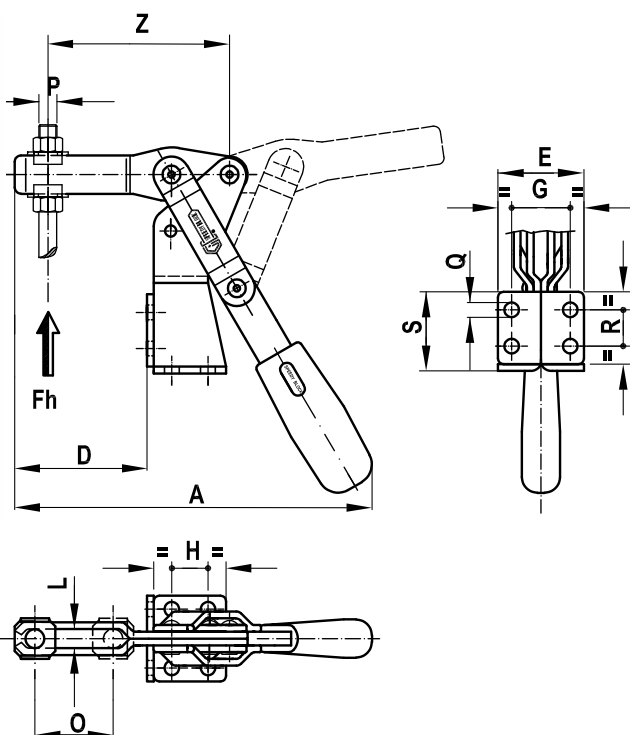

VERTICAL SERIES WITH FOLDED AND FRONT BASE

Material:

Galvanized steel

Riveted pivots:

Galvanized steel

Supporting bushes:

Hardened and ground steel

Handles:

Red polyurethane resistant to oils, grease and other chemical agents.

Performance:

Form AV with open clamping lever and two flanged washers.

Form EV with full clamping lever and bolt retainers to be welded in the desired position and angle.

Spindles:

To be ordered separately

(see Accessories on page 87).

A special grease is placed between two contacting surfaces during assembly.

This series is pneumatically actuated it is found on page 76-77.

FORM EV

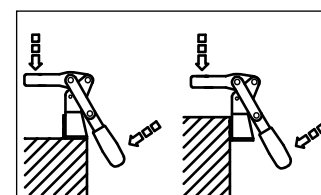
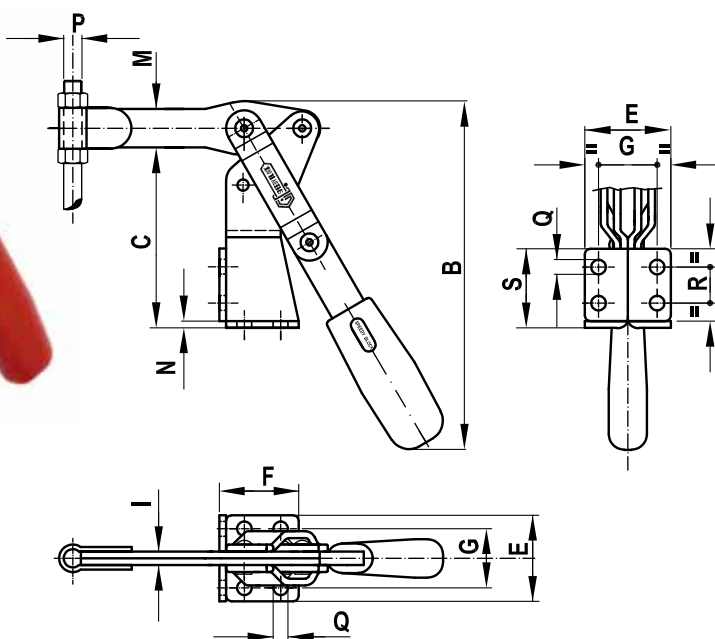

Code	Description	A	B	C	D	E	F	G	H	I	L	M	N	O	P	Q	R	S	Z	Fh (daN)	gr.
AA220	200/AV	157	154	76	58,5	38	35	26	16		8,5	17	3	34	M8	6,5	16	32	86	120	430
AA225	200/EV	159	154	76	60,5	38	35	26	16	6		17	3	M8	6,5	16	32		120	430	
AA320	300/AV	193	198	108	76	48	48	30	28		10,4	20	3	42	M10	8,5	30	51	110	190	800
AA325	300/EV	195	198	108	78	48	48	30	28	8		20	3	M10	8,5	30	51		190	800	