

# LATCH SERIES

## DOUBLE ROD SERIES (LIGHT PERFORMANCE)

The sizes of this series are also produced in stainless steel and are shown below in red.

**Material:** Galvanized steel or **AISI 304 stainless steel**

Riveted pivots and rod: Galvanized steel or **AISI 304 stainless steel**

Swinging pivot: Galvanized steel or **AISI 303 stainless steel**

Handles: Red polyurethane resistant to oils, grease and other chemical agents.

**Performance:** the tool comes with a double bar with hooking bracket and nuts. In addition to the standard length of the U rods, a variety of other lengths are given on page 55. Therefore, when ordering, indicate:

**T3 or T3X** = Tool with Standard Double Threaded Rod and hooking bracket

**T30 or T30X** = Tool without double Threaded rod, which is to be ordered separately (see page 55)

**Features and applications:** The tools of this series ensure a perfect closing of lids. The support base is perpendicular to the force line of action. In the closed position, the control lever is parallel to the support base. A special grease is placed between two contacting surfaces during assembly.

### FORM T3

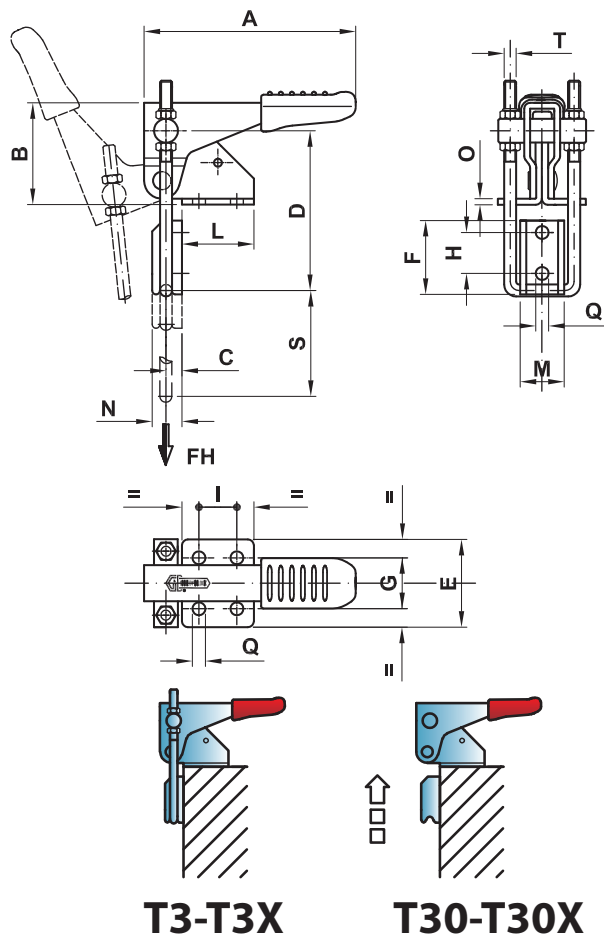
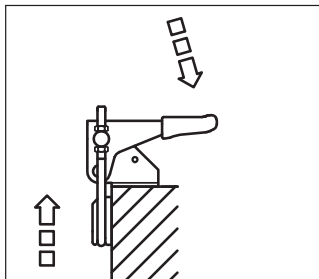

Code	Description	Stainless steel Code	Stainless steel	A	B	C	D	E	F	G	H	I	L	M	N	O	Q	S	T	Fh (daN)	gr.
AL530	160/T3	AS530	160/T3X	68	36	5	48-58	35	25.5	22	14.3	13	26	14	10	2	4.3	34.5	M4	160	100
AL535	320/T3	AS535	320/T3X	106	52.5	8	75-95	44	37	25.5	20.5	19	36	22	15	3	6.5	53	M6	320	320
AL540	700/T3	AS540	700/T3X	147	66	13	98-122	54	48.5	36.5	27	32	52	26	23	3.5	8.5	64	M8	750	680

