

HORIZONTAL SERIES

HORIZONTAL SERIES WITH FOLDED BASE AND WITH SAFETY LEVER

Some sizes of this series are also produced in stainless steel and are shown below in red.

Material: Galvanized steel or **AISI 304 stainless steel**

Riveted pivots: Galvanized steel or **AISI 304 stainless steel**

Supporting bushes:

Hardened and ground steel (for sizes ≥ 355).

Handles:

Red polyurethane resistant to oils, grease and other chemical agents.

Performance: Form ML and **form MLX** with open clamping lever and two flanged washers.

Form OL and **form OLX** with full clamping lever and bolt retainers to be welded in the desired position and angle.

Spindles: To be ordered separately (see Accessories on page 76).

Features and applications: The main feature of this series is the special anti-release lever with the purpose of avoiding any accidental openings caused by vibrations; these tools are designed to prevent the operator's fingers from being crushed by the levers when opening. During the closing, the clamping lever is guided laterally to ensure greater stability against possible transverse stresses. A special grease is placed between two contacting surfaces during assembly.

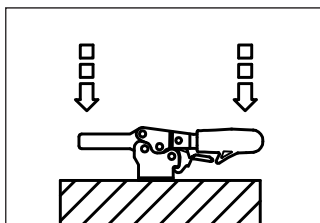

FORM ML

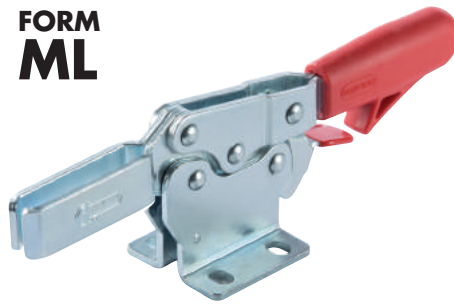

PATENT PENDING

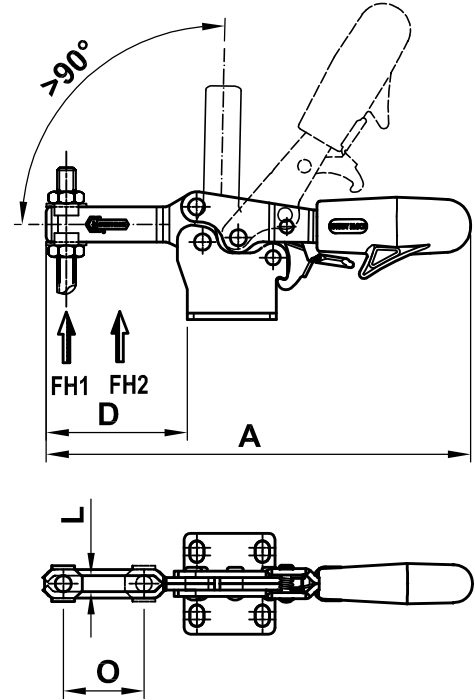

FORM OL

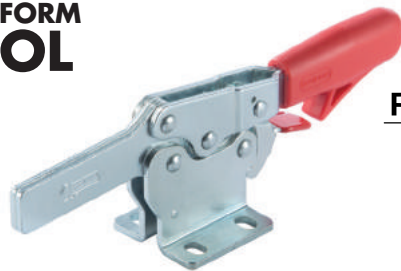

PATENT PENDING

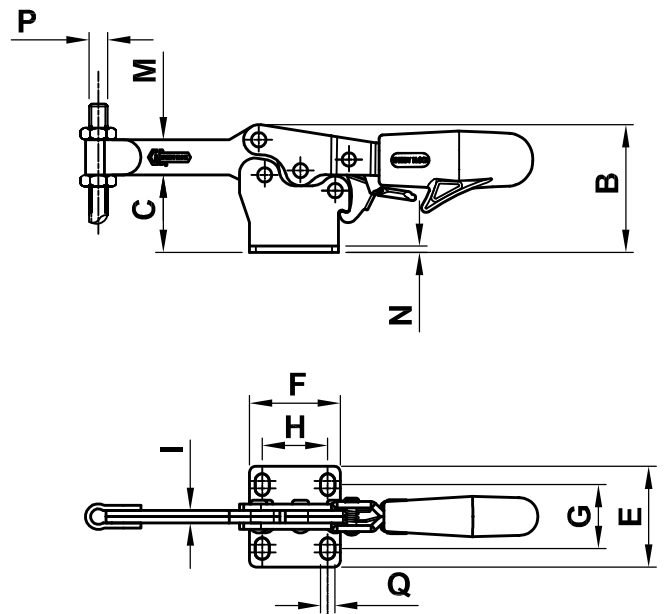

Code	Description	Stainless steel Code	Stainless steel	A	B	C	D	E	F	G	H	I	L	M	N	O	P	Q	Fh1 (daN)	Fh2 (daN)	gr. \triangle
AD092	75/ML	DS100	75/MLX	118	37	20	39	26	28	16-19	13.5	5.3	11	2	20	M5	4.5	90	135	90	
AD096	75/OL	DS104	75/OLX	118.5	37	20	39.5	26	28	16-19	13.5	4	11	2	20	M5	4.5	90	135	90	
AD152	130/ML	DS152	130/MLX	171.5	51	30.5	56.5	40	36	22.4-28.4	26	6.3	16	2.5	32	M6	5.6	100	200	200	
AD156	130/OL	DS156	130/OLX	172	51	30.5	57	40	36	22.4-28.4	26	5	16	2.5	32	M6	5.6	100	200	200	
AD290	230/ML	DS287	230/MLX	196	61.5	36.5	65	44	44	26-31.5	26	8.5	18	3	37	M8	6.6	170	330	320	
AD294	230/OL	DS291	230/OLX	196.5	61.5	36.5	66	44	44	26-31.5	26	6	18	3	37	M8	6.6	170	330	330	
AD390	355/ML			269	83	50	100	58	60	38.8-43	41	10.5	22	3.5	58	M10	8.6	180	400	750	
AD394	355/OL			270	83	50	101	58	60	38.8-43	41	7	22	3.5	58	M10	8.6	180	400	750	
AD490	455/ML			305	99	60	114	65	70	40-43	41.5	12.5	26	4	65	M12	8.7	320	620	1200	
AD494	455/OL			306.5	99	60	115.5	65	70	40-43	41.5	10	26	4	65	M12	8.7	320	620	1220	