

FORM AV

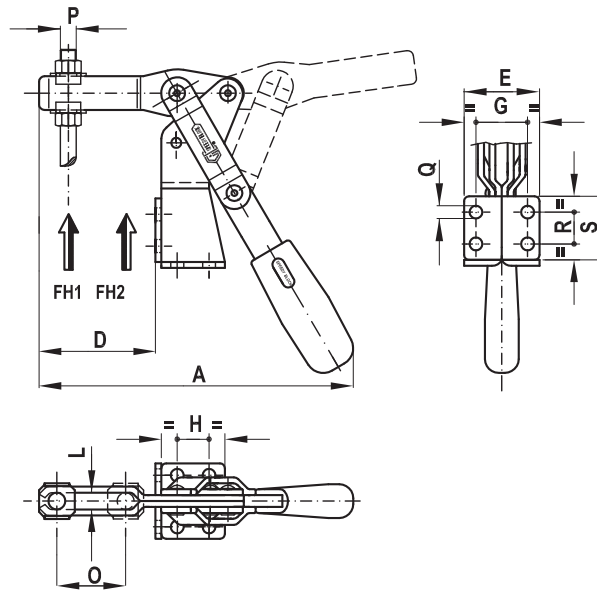

FORM EV

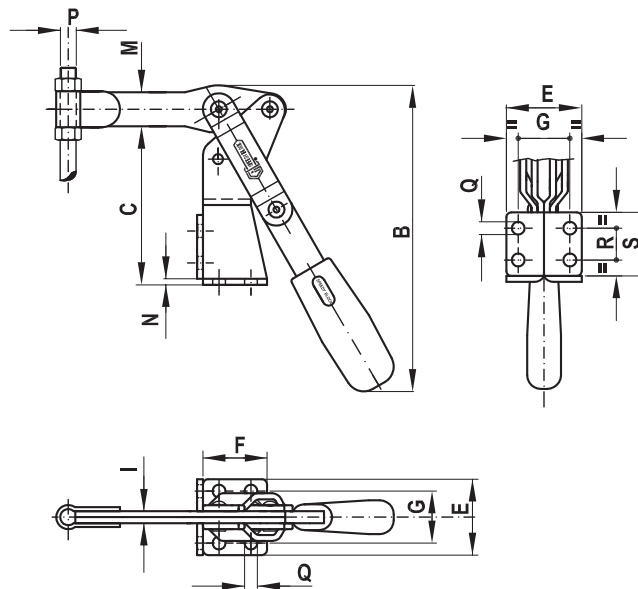

VERTICAL SERIES WITH FOLDED AND FRONT BASE

Material: Galvanized steel
Riveted pivots: Galvanized steel
Supporting bushes: Hardened and ground steel
Handles: Red polyurethane resistant to oils, grease and other chemical agents.
Performance: Form AV with open clamping lever and two flanged washers. Form EV with full clamping lever and bolt retainers to be welded in the desired position and angle.
Spindles: To be ordered separately (see Accessories on page 76).
Features and applications: During the closing, the clamping lever is guided laterally to ensure greater stability against possible transverse stresses. A special grease is placed between two contacting surfaces during assembly. This series is pneumatically actuated it is found on page 70.

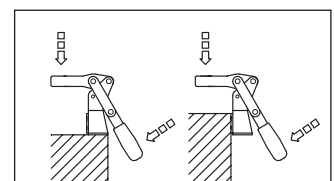

Code	Description	A	B	C	D	E	F	G	H	I	L	M	N	O	P	Q	R	S	Fh1 (daN)	Fh2 (daN)	gr.
AA220	200/AV	157	154	76	58.5	38	32	26	16	8.5	17	3	34	M8	6.5	16	32	120	240	430	
AA225	200/EV	159	154	76	60.5	38	32	26	16	6	17	3		M8	6.5	16	32	120	240	430	
AA320	300/AV	193	198	108	76	48	45	30	28	10.4	20	3	42	M10	8.5	30	48	190	280	800	
AA325	300/EV	195	198	108	78	48	45	30	28	8	20	3		M10	8.5	30	48	190	280	800	