

FORM B

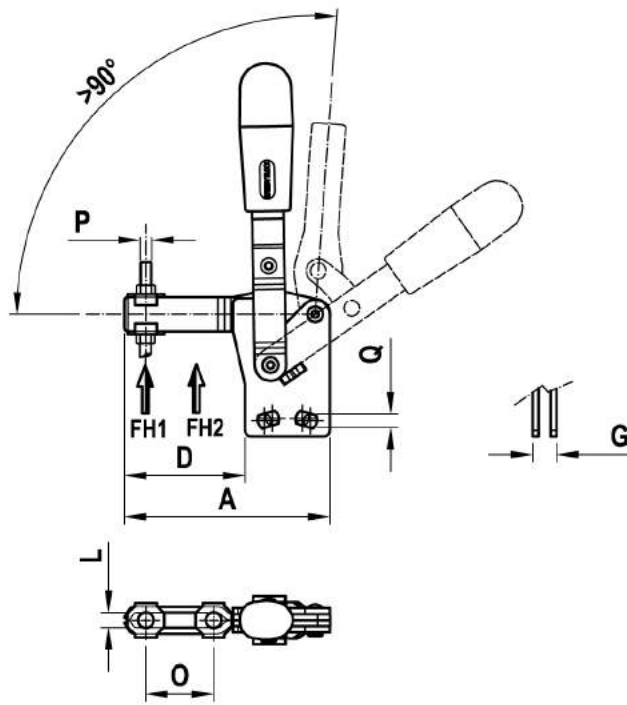

VERTICAL SERIES WITH STRAIGHT BASE

Some sizes of this series are also produced in stainless steel and are shown below in red.

Material:

Galvanized steel or **AISI 304 stainless steel**

Riveted pivots:

Galvanized steel or **AISI 304 stainless steel**

Supporting bushes:

Hardened and ground steel (for sizes ≥ 130)

Handles:

Red polyurethane resistant to oils, grease and other chemical agents.

Performance:

Form B and **form BX** with open clamping lever and two flanged washers. Form F and **form FX** with full clamping lever and bolt retainers to be welded in the desired position and angle.

Spindles:

To be ordered separately (see Accessories on page 76).

Features and applications:

During the closing, the clamping lever is guided laterally to ensure greater stability against possible transverse stresses.

These tools are designed to prevent the operator's fingers from being crushed by the levers when opening.

A special grease is placed between two contacting surfaces during assembly.

FORM F

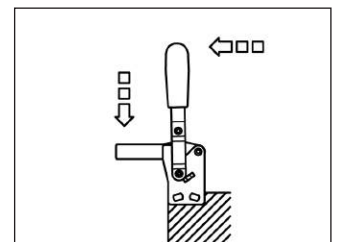
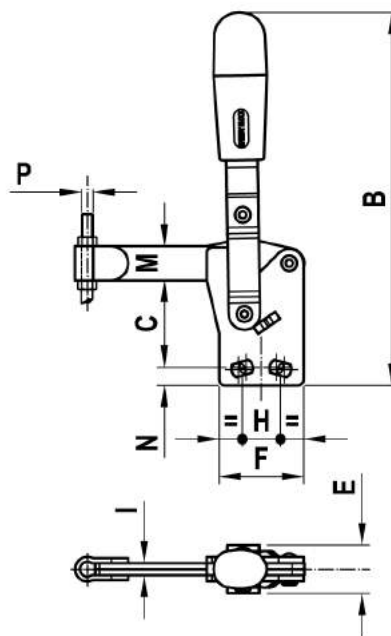

Code	Description	Stainless steel Code	Stainless steel	A	B	C	D	E	F	G	H	I	L	M	N	O	P	Q	Fh1 (daN)	Fh2 (daN)	gr.
AA522	75/B	AS100	75/BX	66.5	109.5	27	37.5	16	29	8	15-16		5.2	11	5	20	M5	4.5	75	160	98
AA526	75/F	AS110	75/FX	67	109.5	27	38	16	29	8	15-16	4		11	5		M5	4.5	75		100
AA532	130/B	AS155	130/BX	85	156	35	50	20	35	10	12.5-19		6.2	16	6.5	28	M6	5.6	105	175	230
AA536	130/F	AS165	130/FX	86	156	35	51	20	35	10	12.5-19	5		16	6.5		M6	5.6	105		235
AA542	230/B	AS185	230/BX	110.5	183	41.5	67.5	23	43	12	19-20		8.5	18	6.5	40	M8	6.7	200	320	380
AA546	230/F	AS195	230/FX	112	183	41.5	69	23	43	12	19-20	6		18	6.5		M8	6.7	200		390
AA552	330/B			129	218	56.5	79	25	50	14	29-32		10.5	22	9.5	43	M10	8.5	240	400	620
AA556	330/F			130.5	218	56.5	80.5	25	50	14	29-32	7		22	9.5		M10	8.5	240		620
AA562	430/B			164	267.5	67.5	106	34	58	18	32		12.5	26	10	64	M12	8.5	280	500	1110
AA566	430/F			166	267.5	67.5	108	34	58	18	32	10		26	10		M12	8.5	280		1110
AA572	530/B			223	337	105	146	34	77	18	50-51		12.5	32	12.5	90	M12	12.5	450	875	1920
AA576	530/F			225	337	105	148	34	77	18	50-51	10		32	12.5		M12	12.5	450		1920